

**NICHE**®

FOR A BETTER US



[www.niche-tool.com](http://www.niche-tool.com)





# CONTENTS

SCREW-IN HOLDERS .....	4
SHOULDERING .....	8
HIGH FEED .....	14
PROFILING .....	15
BALL-NOSE .....	19
MODULAR ENDMILLS .....	22





## ASP SOLID CARBIDE SCREW-IN HOLDER

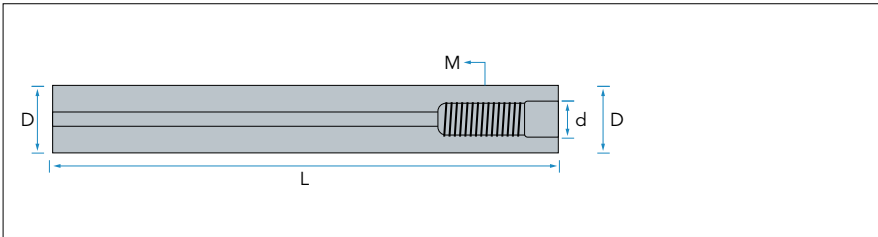

Part No.	D	D1	d	M	L
ASP-8-100-M4	8	8	4,5	M4	100
ASP-8-150-M4	8	8	4,5	M4	150
ASP-10-100-M5	10	10	5,5	M5	100
ASP-10-150-M5	10	10	5,5	M5	150
ASP-10-100-M6	10	10	6,5	M6	100
ASP-10-150-M6	10	10	6,5	M6	150
ASP-11-100-M6	11	11	6,5	M6	100
ASP-11-150-M6	11	11	6,5	M6	150
ASP-12-100-M6	12	12	6,5	M6	100
ASP-12-150-M6	12	12	6,5	M6	150
ASP-12-200-M6	12	12	6,5	M6	200
ASP-14-100-M8	14	14	8,5	M8	100
ASP-14-150-M8	14	14	8,5	M8	150
ASP-14-200-M8	14	14	8,5	M8	200
ASP-15-100-M8	15	15	8,5	M8	100
ASP-15-150-M8	15	15	8,5	M8	150
ASP-15-200-M8	15	15	8,5	M8	200
ASP-15-250-M8	15	15	8,5	M8	250
ASP-15.6-100-M8	15,6	15,6	8,5	M8	100
ASP-15.6-150-M8	15,6	15,6	8,5	M8	150
ASP-15.6-200-M8	15,6	15,6	8,5	M8	200
ASP-15.6-250-M8	15,6	15,6	8,5	M8	250
ASP-16-100-M8	16	16	8,5	M8	100

Part No.	D	D1	d	M	L
ASP-16-150-M8	16	16	8,5	M8	150
ASP-16-200-M8	16	16	8,5	M8	200
ASP-16-250-M8	16	16	8,5	M8	250
ASP-16-300-M8	16	16	8,5	M8	300
ASP-16-350-M8	16	16	8,5	M8	350
ASP-18-130-M10	18	18	10,5	M10	130
ASP-18-200-M10	18	18	10,5	M10	200
ASP-18-250-M10	18	18	10,5	M10	250
ASP-19-100-M10	19	19	10,5	M10	100
ASP-19-150-M10	19	19	10,5	M10	150
ASP-19-200-M10	19	19	10,5	M10	200
ASP-19-250-M10	19	19	10,5	M10	250
ASP-19-300-M10	19	19	10,5	M10	300
ASP-20-100-M10	20	20	10,5	M10	100
ASP-20-150-M10	20	20	10,5	M10	150
ASP-20-200-M10	20	20	10,5	M10	200
ASP-20-250-M10	20	20	10,5	M10	250
ASP-20-300-M10	20	20	10,5	M10	300
ASP-20-350-M10	20	20	10,5	M10	350
ASP-23-150-M12	23	23	12,5	M12	150
ASP-23-200-M12	23	23	12,5	M12	200
ASP-23-250-M12	23	23	12,5	M12	250
ASP-23-300-M12	23	23	12,5	M12	300



ASP SOLID CARBIDE SCREW-IN HOLDER

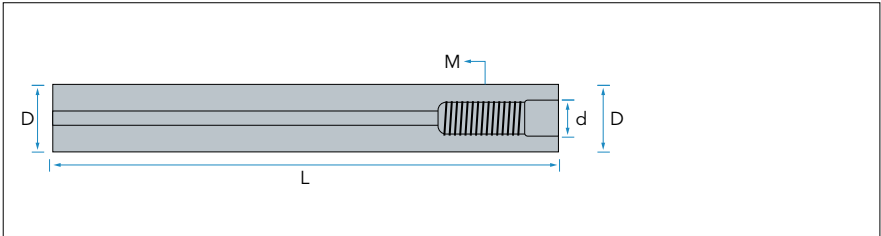

Part No.	D	D1	d	M	L
ASP-24-150-M12	24	24	12,5	M12	150
ASP-24-200-M12	24	24	12,5	M12	200
ASP-24-250-M12	24	24	12,5	M12	250
ASP-24-300-M12	24	24	12,5	M12	300
ASP-25-100-M12	25	25	12,5	M12	100
ASP-25-150-M12	25	25	12,5	M12	150
ASP-25-200-M12	25	25	12,5	M12	200
ASP-25-250-M12	25	25	12,5	M12	250
ASP-25-300-M12	25	25	12,5	M12	300
ASP-25-350-M12	25	25	12,5	M12	350
ASP-28-150-M16	28	28	17	M16	150
ASP-28-200-M16	28	28	17	M16	200
ASP-28-250-M16	28	28	17	M16	250
ASP-28-300-M16	28	28	17	M16	300
ASP-28-350-M16	28	28	17	M16	350
ASP-32-100-M16	32	32	17	M16	100
ASP-32-150-M16	32	32	17	M16	150
ASP-32-200-M16	32	32	7	M16	200
ASP-32-250-M16	32	32	17	M16	250
ASP-32-300-M16	32	32	17	M16	300
ASP-32-350-M16	32	32	17	M16	350
ASP-32-400-M16	32	32	17	M16	400
ASP-32-450-M16	32	32	17	M16	450

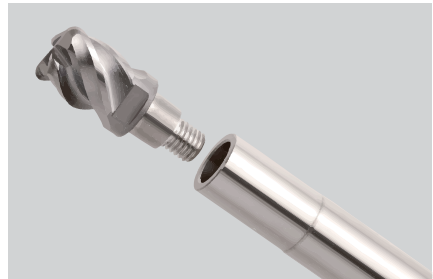

INSTALLING AN INTERCHANGABLE CUTTER

- To clean the clamp section of the cutter and holder/ arbor with an air blower or brush before installation.
- To tighten the cutter at the recommended torque and ensure that there is no gap between the cutter and holder/arbor.



## BT SCREW-IN ARBOR

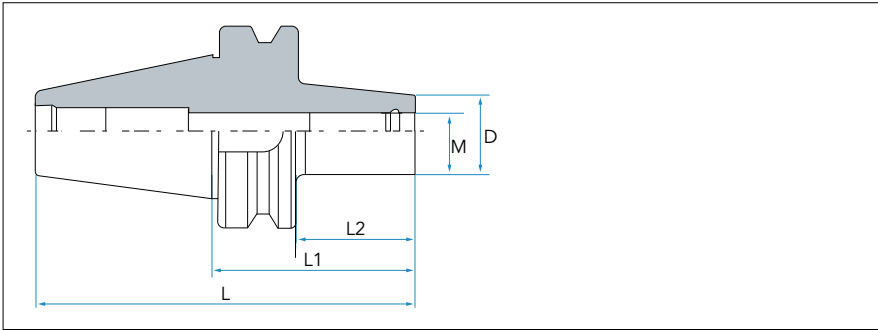

Part No.	L	L1	L2	D	M
BT30-LTM6-60	108,4	60	38	13	M6*1.0
BT30-LTM8-60	108,4	60	38	15	M8*1.25
BT30-LTM10-60	108,4	60	38	19	M10*1.5
BT30-LTM12-60	108,4	60	38	24	M12*1.75
BT30-LTM16-60	108,4	60	38	29	M16*2.0
BT40-LTM6-60	125,4	60	33	13	M6*1.0
BT40-LTM8-60	125,4	60	33	15	M8*1.25
BT40-LTM10-60	125,4	60	33	19	M10*1.5
BT40-LTM12-60	125,4	60	33	24	M12*1.75
BT40-LTM16-60	125,4	60	33	29	M16*2.0
BT50-LTM8-100	201,8	100	62	15	M8*1.25
BT50-LTM10-100	201,8	100	62	19	M10*1.5
BT50-LTM12-100	201,8	100	62	24	M12*1.75
BT50-LTM16-100	201,8	100	62	29	M16*2.0



HSK SCREW-IN ARBOR

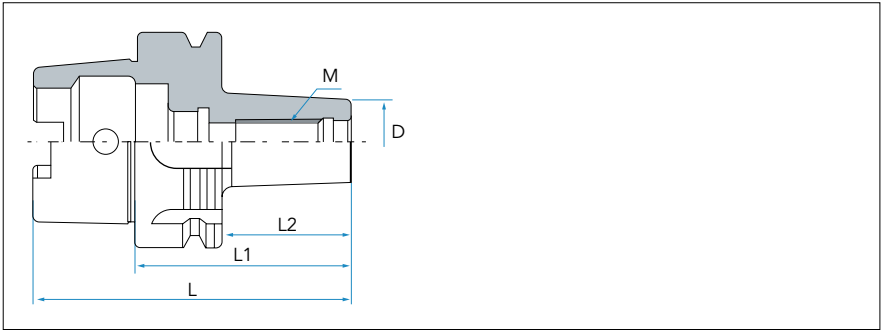

Part No.	L	L1	L2	D	M
HSK63A-LTM6-60	92	60	34	13	M6*1.0
HSK63A-LTM8-60	92	60	34	15	M8*1.25
HSK63A-LTM10-60	92	60	34	19	M10*1.5
HSK63A-LTM12-70	102	70	44	24	M12*1.75
HSK63A-LTM16-80	112	80	54	29	M16*2.0
HSK100A-LTM6-60	92	60	31	13	M6*1.0
HSK100A-LTM8-60	92	60	31	15	M8*1.25
HSK100A-LTM10-60	92	60	31	19	M10*1.5
HSK100A-LTM12-70	102	70	41	24	M12*1.75
HSK100A-LTM16-80	112	80	51	29	M16*2.0



**BAP-AP11/16** — MITSUBISHI INSERT

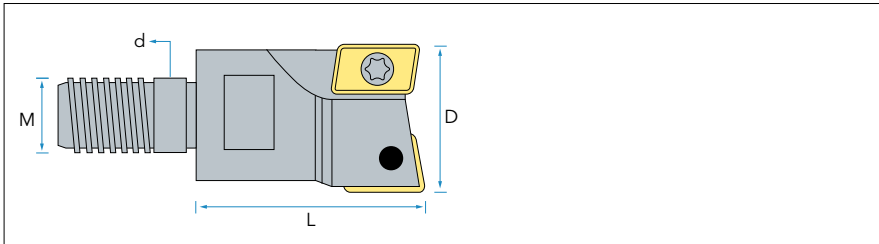

Part No.	Teeth	Dimensions				Insert	Screw	Wrench
		D	d	L	M			
BAP3-10-1T-M5	1	10	5,5	20	M5	AP**1135	M2.5*6	T8
BAP3-11-1T-M5	1	11	5,5	20	M5			
BAP3-12-1T-M6	1	12	6,5	20	M6			
BAP3-13-1T-M6	1	13	6,5	20	M6			
BAP3-16-2T-M8	2	16	8,5	25	M8			
BAP3-17-2T-M8	2	17	8,5	25	M8			
BAP3-20-2T-M10	2	20	10,5	30	M10			
BAP3-21-2T-M10	2	21	10,5	30	M10			
BAP3-20-3T-M10	3	20	10,5	30	M10			
BAP3-21-3T-M10	3	21	10,5	30	M10			
BAP3-25-3T-M12	3	25	12,5	35	M12			
BAP3-26-3T-M12	3	26	12,5	35	M12			
BAP3-33-4T-M16	4	33	17	40	M16			
BAP3-35-4T-M16	4	35	17	40	M16			
BAP4-25-2T-M12	2	25	12,5	35	M12	AP**1604	M4*9	T15
BAP4-26-2T-M12	2	26	12,5	35	M12			
BAP4-30-2T-M12	2	30	12,5	35	M12			
BAP4-32-2T-M16	2	32	17	40	M16			
BAP4-33-3T-M16	3	33	17	40	M16			
BAP4-35-3T-M16	3	35	17	40	M16			
BAP4-40-3T-M16	3	40	17	40	M16			





AP-AP09/17 — TAEGUTEC INSERT

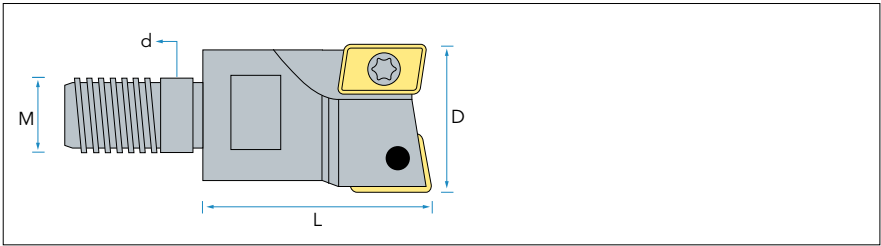

Part No.	Teeth	Dimensions				Insert	Screw	Wrench
		D	d	L	M			
AP09T3-16-2T-M8	2	16	8,5	25	M8	AP**09T3	M2.5*6	T8
AP09T3-17-2T-M8	2	17	8,5	25	M8			
AP09T3-20-2T-M10	2	20	10,5	30	M10			
AP09T3-21-2T-M10	2	21	10,5	30	M10			
AP09T3-20-3T-M10	3	20	10,5	30	M10			
AP09T3-21-3T-M10	3	21	10,5	30	M10			
AP09T3-25-2T-M12	3	25	12,5	35	M12			
AP09T3-26-2T-M12	3	26	12,5	35	M12			
AP1705-25-2T-M12	2	25	12,5	35	M12	AP**1705	M4*9	T15
AP1705-26-2T-M12	2	26	12,5	35	M12			



**AX0602** — TAEGUTEC INSERT

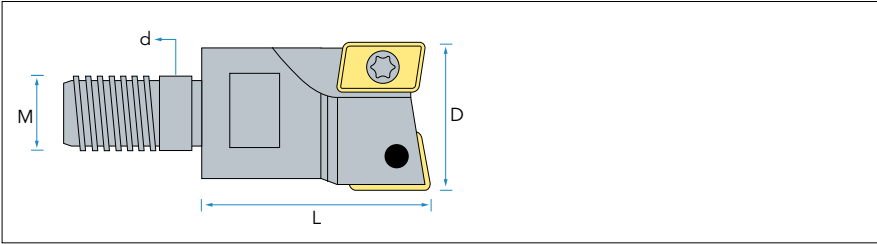

Part No.	Teeth	Dimensions				Insert	Screw	Wrench
		D	d	L	M			
AX0602-8-1T-M4	1	8	4,5	15	M4	AX**0602	M1.8*4	T6
AX0602-9-1T-M4	1	9	4,5	15	M4			
AX0602-10-2T-M5	2	10	5,5	20	M5			
AX0602-11-2T-M5	2	11	5,5	20	M5			
AX0602-12-2T-M6	2	12	6,5	20	M6			
AX0602-13-2T-M6	2	13	6,5	20	M6			

**JD0702** — HITACH INSERT

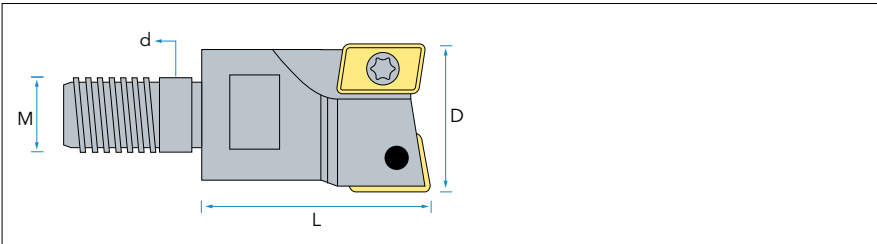

Part No.	Teeth	Dimensions				Insert	Screw	Wrench
		D	d	L	M			
JD0702-8-1T-M4	1	8	4,5	15	M4	JD**0702	M1.8*4	MT6
JD0702-9-1T-M4	1	9	4,5	15	M4			
JD0702-10-2T-M5	2	10	5,5	20	M5			
JD0702-11-2T-M5	2	11	5,5	20	M5			
JD0702-12-2T-M6	2	12	6,5	20	M6			
JD0702-13-2T-M6	2	13	6,5	20	M6			



JD-10/15 — HITACH INSERT

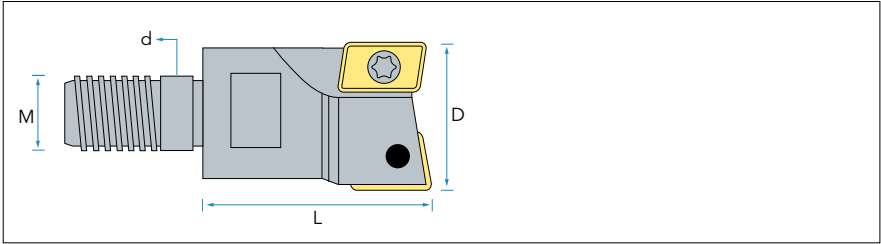

Teeth	Dimensions				Insert	Screw	Wrench	Wrench
	D	d	L	M				
JD1003-16-2T-M8	2	16	8,5	25	M8	JD**1003	M2.5*6	T8
JD1003-17-2T-M8	2	17	8,5	25	M8			
JD1003-20-2T-M10	2	20	10,5	30	M10			
JD1003-21-2T-M10	2	21	10,5	30	M10			
JD1003-25-3T-M12	3	25	12,5	35	M12			
JD1003-26-3T-M12	3	26	12,5	35	M12	JD**1505	M4*9	T15
JD1505-25-2T-M12	2	25	12,5	35	M12			
JD1505-26-2T-M12	2	26	12,5	35	M12			



**R390-11** — SANDVIK INSERT

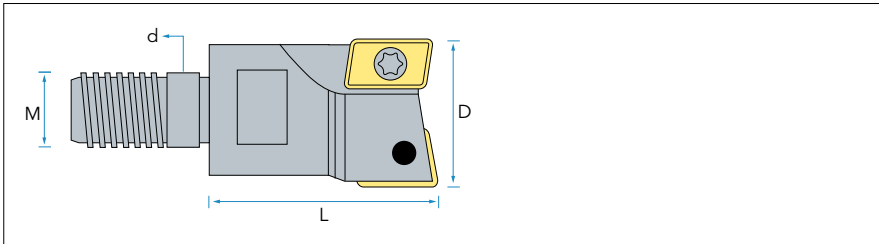

Part No.	Teeth	Dimensions				Insert	Screw	Wrench
		D	d	L	M			
R39011-16-2T-M8	2	16	8,5	25	M8	R390-11T3	M2.5*6	T8
R39011-17-2T-M8	2	17	8,5	25	M8			
R39011-20-2T-M10	2	20	10,5	30	M10			
R39011-21-2T-M10	2	21	10,5	30	M10			
R39011-25-2T-M12	2	25	12,5	35	M12			
R39011-26-2T-M12	2	26	12,5	35	M12			
R39011-25-3T-M12	3	25	12,5	35	M12			
R39011-26-3T-M12	3	26	12,5	35	M12			
R39011-32-4T-M16	4	32	17	40	M16			
R39011-33-4T-M16	4	33	17	40	M16			
R39011-35-4T-M16	4	35	17	40	M16			



**AP1035** — SUMITOMO INSERT

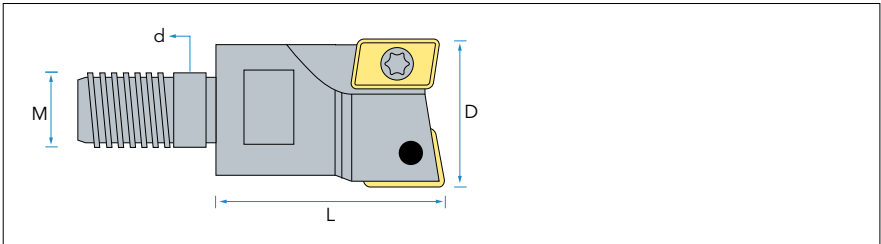

Part No.	Teeth	Dimensions				Insert	Screw	Wrench
		D	d	L	M			
AP1035-16-2T-M8	2	16	8,5	25	M8	AP**1035	M2.5*6	T8
AP1035-17-2T-M8	2	17	8,5	25	M8			
AP1035-20-2T-M10	2	20	10,5	30	M10			
AP1035-21-2T-M10	2	21	10,5	30	M10			
AP1035-25-3T-M12	3	25	12,5	35	M12			
AP1035-26-3T-M12	3	26	12,5	35	M12			

**XO0602** — SECO INSERT

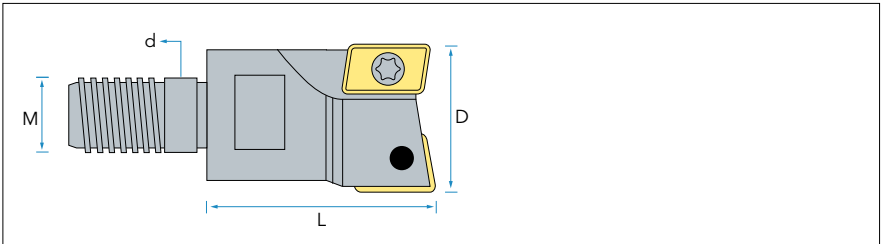

Part No.	Teeth	Dimensions				Insert	Screw	Wrench
		D	d	L	M			
XO0602-10-2T-M5	2	10	5,5	20	M5	XO**0602	M1.8*4	T16
XO0602-11-2T-M5	2	11	5,5	20	M5			
XO0602-12-2T-M6	2	12	6,5	20	M6			
XO0602-13-2T-M6	2	13	6,5	20	M6			



**EP0603** — HITACHI INSERT

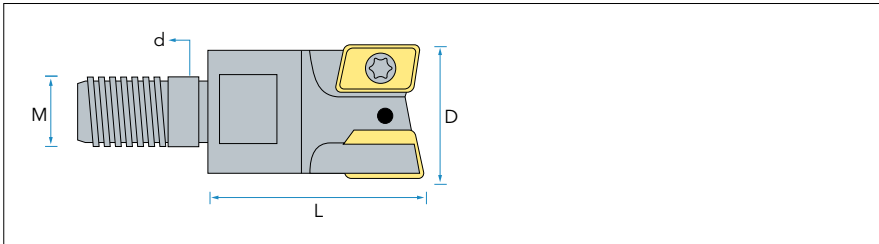

Part No.	Teeth	Dimensions				Insert	Screw	Wrench
		D	d	L	M			
EP0603-16-2T-M8	2	16	8,5	25	M8	EP**0603	M2.5*6	T8
EP0603-17-2T-M8	2	17	8,5	25	M8			
EP0603-20-2T-M10	2	20	10,5	30	M10			
EP0603-21-2T-M10	2	21	10,5	30	M10			
EP0603-25-3T-M12	3	25	12,5	35	M12			
EP0603-26-3T-M12	3	26	12,5	35	M12			



**EMRM** — MITSUBISHI INSERT

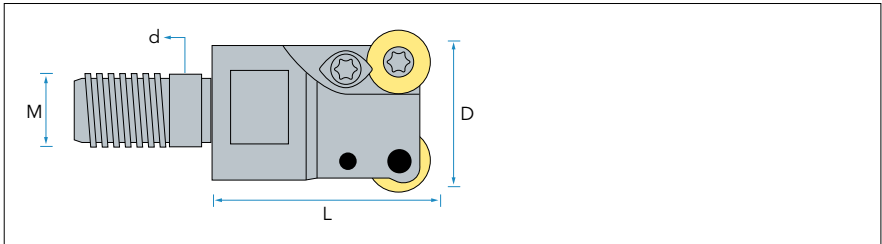

Part No.	Teeth	Dimensions				Insert	Clamp	Screw	Wrench
		D	d	L	M				
EMRM-4R16-2T-M8	2	16	8,5	25	M8	RP**0802	4R	M3*7	T8
EMRM-4R17-2T-M8	2	17	8,5	25	M8				
EMRM-4R20-2T-M10	2	20	10,5	30	M10				
EMRM-4R21-2T-M10	2	21	10,5	30	M10				
EMRM-5R20-2T-M10	2	20	10,5	30	M10	RP**1003	5R	M4*9	T15
EMRM-5R21-2T-M10	2	21	10,5	30	M10				
EMRM-5R25-2T-M12	2	25	12,5	35	M12				
EMRM-5R26-2T-M12	2	26	12,5	35	M12				
EMRM-5R30-2T-M12	2	30	12,5	35	M12				
EMRM-5R32-3T-M16	3	32	17	40	M16				
EMRM-5R35-3T-M16	3	35	17	40	M16				
EMRM-5R40-4T-M16	4	40	17	40	M16				
EMRM-6R35-3T-M16	3	35	17	40	M16	RP**1204	6R	M4*10	
EMRM-6R40-3T-M16	3	40	17	40	M16				



RD-07/10 — DIJET INSERT

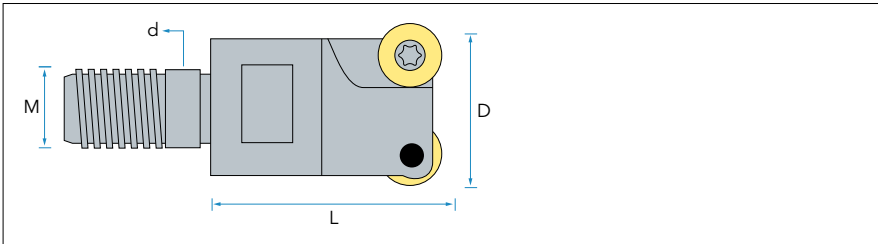

Part No.	Teeth	Dimensions				Insert	Clamp	Screw	Wrench
		D	d	L	M				
RD0702-16-2T-M8	2	16	8,5	25	M8	RD**0702	M2.5*6	T8	
RD0702-17-2T-M8	2	17	8,5	25	M8				
RD0702-20-3T-M10	3	20	10,5	30	M10				
RD0702-21-3T-M10	3	21	10,5	30	M10				
RD0702-25-4T-M12	4	25	12,5	35	M12				
RD0702-26-4T-M12	4	26	12,5	35	M12				
RD0702-33-4T-M16	4	33	17	40	M16				
RD0702-35-4T-M16	4	35	17	40	M16				
RD1003-20-2T-M10	2	20	10,5	30	M10	RD**1003	M3.5*9	T15	
RD1003-21-2T-M10	2	21	10,5	30	M10				
RD1003-25-2T-M12	2	25	12,5	35	M12				
RD1003-26-2T-M12	2	26	12,5	35	M12				





RC-10/12 — SANDVIK INSERT

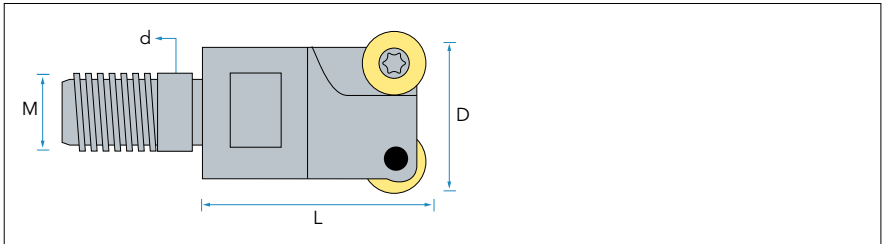

Part No.	Teeth	Dimensions				Insert	Clamp	Screw	Wrench
		D	d	L	M				
RC10T3-25-2T-M12	2	25	12,5	35	M12	RC**10T3	-	M3.5*9	T15
RC10T3-26-2T-M12	2	26	12,5	35	M12			M3.5*10	
RC1204-32-2T-M16	2	32	17	35	M16	RC**1204	M3.5*10		
RC1204-35-2T-M16	2	35	17	40	M16				



**TRSM** — HITACHI INSERT

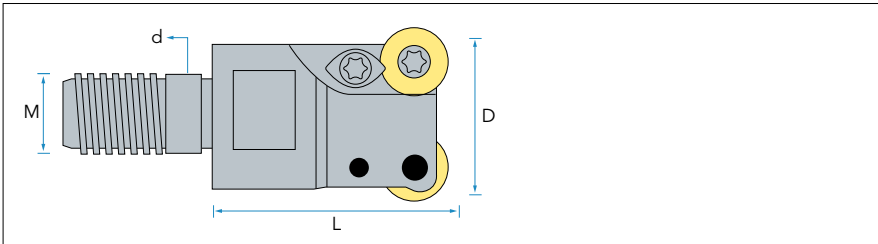

Part No.	Teeth	Dimensions				Insert	Clamp	Screw	Wrench
		D	d	L	M				
TRSM-4R16-2T-M8	2	16	8,5	25	M8	RD**0802	4R	M3*7	T8
TRSM-4R17-2T-M8	2	17	8,5	25	M8				
TRSM-4R20-2T-M10	2	20	10,5	30	M10				
TRSM-4R21-2T-M10	2	21	10,5	30	M10				
TRSM-5R20-2T-M10	2	20	10,5	30	M10	RD**10T3	5R	M4*9	T15
TRSM-5R21-2T-M10	2	21	10,5	30	M10				
TRSM-5R25-2T-M12	2	25	12,5	35	M12				
TRSM-5R26-2T-M12	2	26	12,5	35	M12				
TRSM-5R30-2T-M12	2	30	12,5	35	M12				
TRSM-5R32-3T-M16	3	32	17	40	M16				
TRSM-5R35-3T-M16	3	35	17	40	M16				
TRSM-5R40-4T-M16	4	40	17	40	M16				



**WGR** — WALTER INSERT

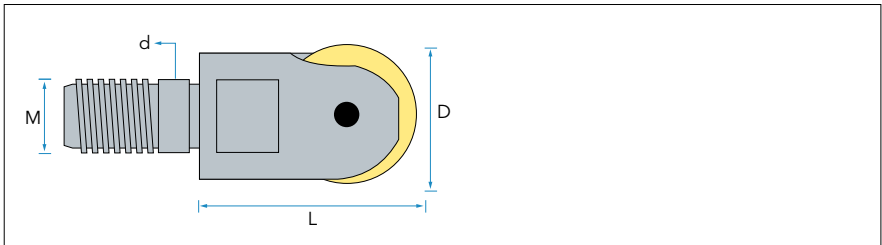

Part No.	Teeth	Dimensions				Insert	Screw	Wrench
		D	d	L	M			
WGR08-M4	1	8	4,5	15	M4	P320*-D08	WGR-4R	T15
WGR10-M5	1	10	5,5	20	M5	P320*-D10	WGR-5R	T15
WGR12-M6	1	12	6,5	20	M6	P320*-D12	WGR-6R	T20
WGR16-M8	1	16	8,5	25	M8	P320*-D16	WGR-8R	T20
WGR20-M10	1	20	10,5	30	M10	P320*-D20	WGR-10R	T20
WGR25-M12	1	25	12,5	35	M12	P320*-D25	WGR-12.5R	T20
WGR30-M16	1	30	17	40	M16	P320*-D30	WGR-15R	T25

**ABPF** — HITACHI INSERT

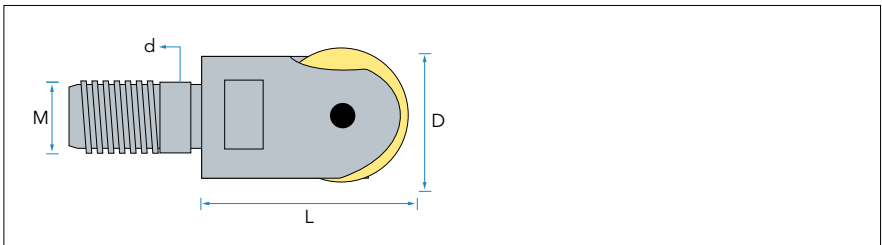

Part No.	Teeth	Dimensions				Insert	Screw	Wrench
		D	d	L	M			
ABPF-10-M5	1	10	5,5	20	M5	ZPFG-100	ABPF-5R	T10
ABPF-12-M6	1	12	6,5	20	M6	ZPFG-120	ABPF-6R	T20
ABPF-16-M8	1	16	8,5	25	M8	ZPFG-160	ABPF-8R	T20
ABPF-20-M10	1	20	10,5	30	M10	ZPFG-200	ABPF-10R	T20
ABPF-25-M12	1	25	12,5	35	M12	ZPFG-250	ABPF-12.5R	T25
ABPF-30-M16	1	30	17	40	M16	ZPFG-300	ABPF-15	T30



## BNM — DIJET INSERT

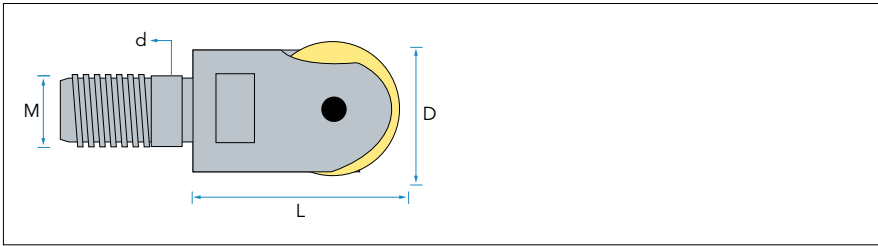

Part No.	Teeth	Dimensions				Insert	Screw	Wrench
		D	d	L	M			
BNM-08-M4	1	8	4,5	15	M4	BNM-080	BNM-4R	T8
BNM-10-M5	1	10	5,5	20	M5	BNM-100	BNM-5R	T8
BNM-12-M6	1	12	6,5	20	M6	BNM-120	BNM-6R	T10
BNM-16-M8	1	16	8,5	25	M8	BNM-160	BNM-8R	T15
BNM-20-M10	1	20	10,5	30	M10	BNM-200	BNM-10R	T20
BNM-25-M12	1	25	12,5	35	M12	BNM-250	BNM-12.5R	T25
BNM-30-M16	1	30	17	40	M16	BNM-300	BNM-15R	T30

## ARPF — HITACHI INSERT

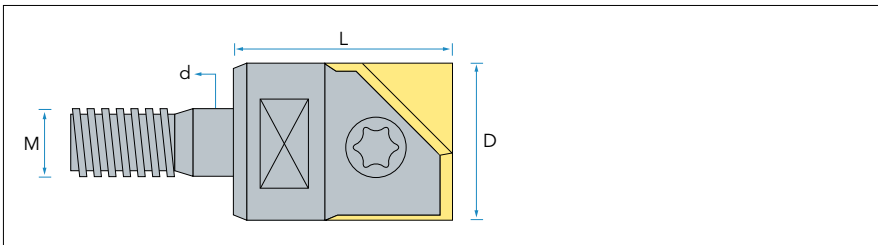

Part No.	Teeth	Dimensions				Insert	Screw	Wrench
		D	d	L	M			
ARPF-16-M8	1	16	8,5	25	M8	ZCFW-160	ABPF-8R	T20
ARPF-20-M10	1	20	10,5	30	M10	ZCFW-200	ABPF-10R	T20
ARPF-25-M12	1	25	12,5	35	M12	ZCFW-250	ABPF-12.5R	T25
ARPF-30-M16	1	30	17	40	M16	ZCFW-300	ABPF-15R	T30



**RNM** — DIJET INSERT

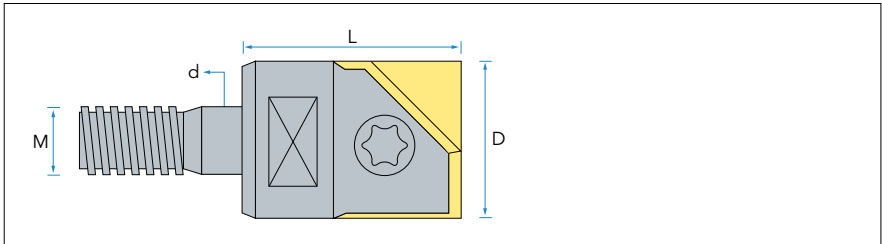

Part No.	Teeth	Dimensions				Insert	Screw	Wrench
		D	d	L	M			
RNM-12-M6	1	12	6,5	20	M6	RNM-120	RNM-6R	T10
RNM-16-M8	1	16	8,5	25	M8	RNM-160	RNM-8R	T15
RNM-20-M10	1	20	10,5	30	M10	RNM-200	RNM-10R	T20
RNM-25-M12	1	25	12,5	35	M12	RNM-250	RNM-12.5R	T25
RNM-30-M16	1	30	17	40	M16	RNM-300	RNM-15R	T30



## SQUARE HEAD — 4 FLUTES

Part No.	Dimensions			
	Dc	L2	L3	D1
MNGP-E0804-M4	8	8,1	19	7,6
MNGP-E1004-M5	10	10,1	22	9,6
MNGP-E1204-M6	12	12,1	26	11,6
MNGP-E1604-M8	16	16,1	32,5	15,6
MNGP-E2004-M10	20	20,1	38,5	19,6
MNGP-E2504-M12	25	25,1	46	24,6



## BALL NOSE — 2 FLUTES

Part No.	Dimensions				
	Dc	R	L2	L3	D1
MNGP-B0802-M4	8	4	8,1	19	7,6
MNGP-B1002-M5	10	5	10,1	22	9,6
MNGP-B1202-M6	12	6	12,1	26	11,6
MNGP-B1602-M8	16	8	16,1	32,5	15,6
MNGP-B2002-M10	20	10	20,1	38,5	19,6
MNGP-B2502-M12	25	12,5	25,1	46	24,6

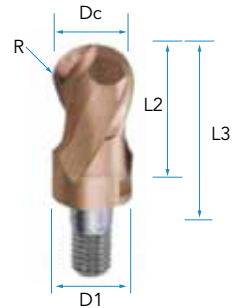

## CORNER RADIUS — 4 FLUTES

Part No.	Dimensions				
	Dc	R	L2	L3	D1
MNGP-RB0805-M4	8	0,5	8,1	19	7,6
MNGP-RB1005-M5	10	0,5	10,1	22	9,6
MNGP-RB1205-M6	12	0,5	12,1	26	11,6
MNGP-RB1605-M8	16	0,5	16,1	32,5	15,6
MNGP-RB2005-M10	20	0,5	20,1	38,5	19,6
MNGP-RB2505-M12	25	0,5	25,1	46	24,6

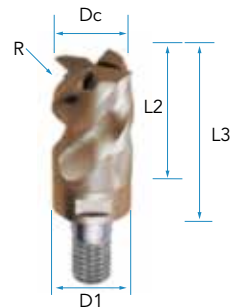

# MEMO

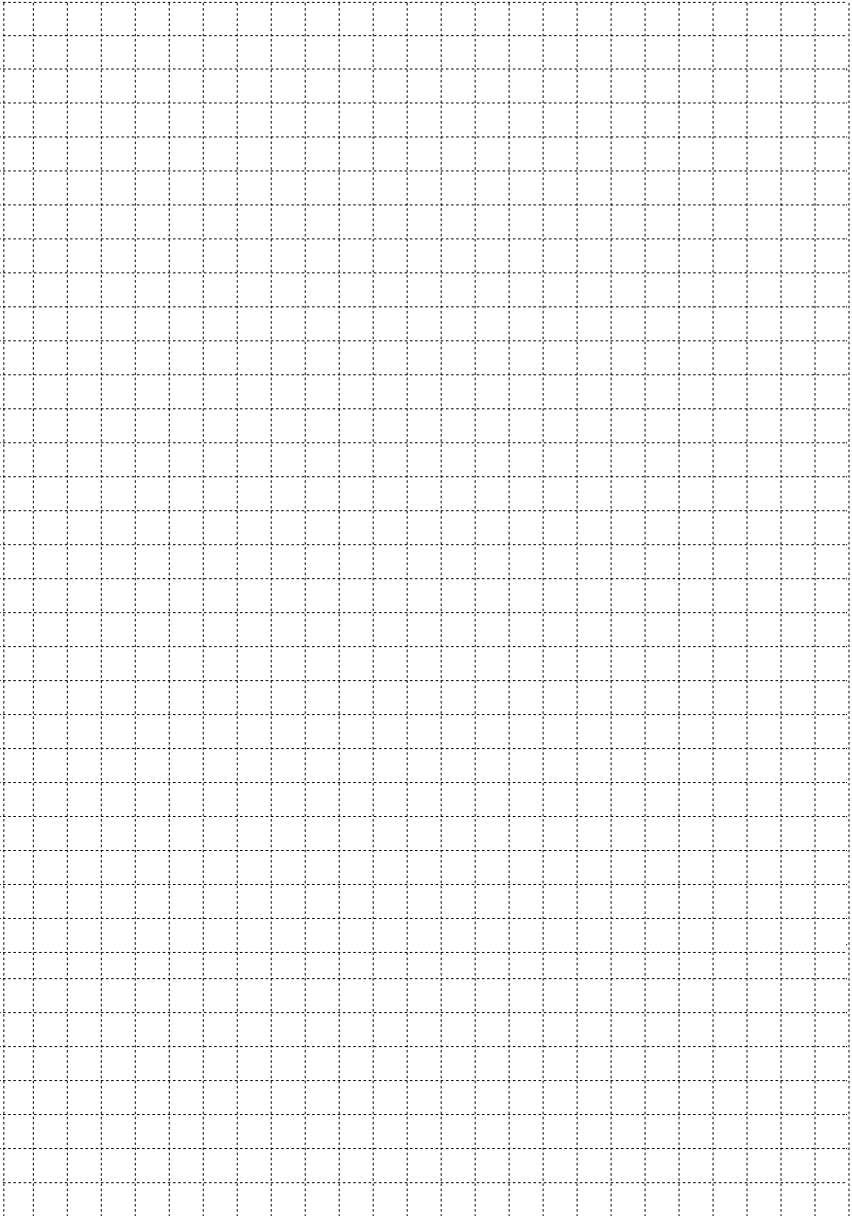



**ADDRESS**

ROOM 1601, NO. 399 MINHE ROAD, ZHENHAI,  
NINGBO CHINA, 315202

**GET IN TOUCH**

PHONE: **+86 574 8659 2189**

FAX: **+86 574 8659 3892**

**NTTOOLS2017@GMAIL.COM**

**WWW.NICHE-TOOL.COM**